

FIVC Gate Valve

Ductile Iron – PN 25 – Non Rising Stem – WRAS – EN 1092-2



FGA series



Technical data

Main features and materials

- Body: Ductile Iron
- Bonnet: Ductile Iron
- Wedge: Ductile Iron+EPDM
- Stem: Stainless Steel
- Handwheel: Ductile Iron
- Coating: Epoxy
- Drilling: EN 1092-2 PN 25
- Design: Face-to-Face acc. to BS 5163
- Testing: BS EN 12266-1
- USP:
 - Shell pressure: 3.75 MPa
 - Sealing pressure: 2.75 MPa
 - Drinking water approved
 - Excellent tightness
 - Minimum pressure loss
 - Long lifetime

Field of applications

- Temperature range: -10 to 85 °C
- Non-WRAS: -10 to 100 °C
- Max. working pressure: 25 bar
- Drinking water
 - Other various industries

Description

FIVC Gate Valve is designed to be installed in pipelines only for isolating purposes.

Benefits of using the gate valves include the feature of good closing along with the minimum pressure loss, since the gate valve, when fully open, has no obstruction in the flow path. Further, the opening and closing operation is slow and proportional and requires multiple turnings of the handwheel, preventing the water hammer phenomenon.

The gate valve provides a shut-off function and should operate in fully open or fully closed positions and should not be used as a control-, or regulating valve.

This valve is suitable for Drinking Water.

Declaration

The product has been manufactured and tested in accordance with the European PED Directive N° 2014/68/EU, dated 15/05/2014 and is CE marked.



Dimensions

DN 40-400

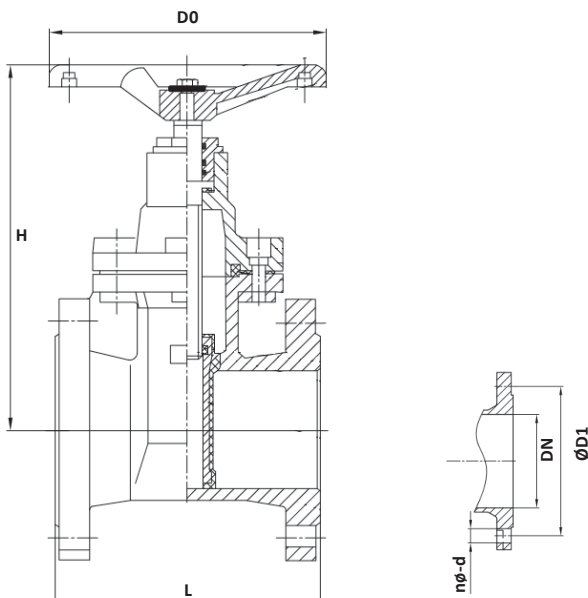

Product code	Size	L	H	D1	D0	n-ø-d	Kg
FGA040N25NB231	40	178	210	110	160	4-ø19	7
FGA050N25NB231	50	178	236	125	160	4-ø19	9
FGA065N25NB231	65	190	249	145	160	8-ø19	11
FGA080N25NB231	80	203	275	160	180	8-ø19	13
FGA100N25NB231	100	229	322	190	200	8-ø23	18
FGA125N25NB231	125	254	377	220	250	8-ø28	35
FGA150N25NB231	150	267	424	250	250	8-ø28	40
FGA200N25NB231	200	292	500	310	300	12-ø28	67
FGA250N25NB231	250	330	591	370	350	12-ø31	102
FGA300N25NB231	300	356	695	430	400	16-ø31	140
FGA350N25NB231	350	381	785	490	500	16-ø34	190
FGA400N25NB231	400	406	895	550	500	16-ø37	277

Dimensions are in millimeters. Size 350 and 400 are without CE-marking

FIVC Gate Valve

Ductile Iron – PN 25 – Non Rising Stem – WRAS – EN 1092-2

DN 40-400

Product Specification

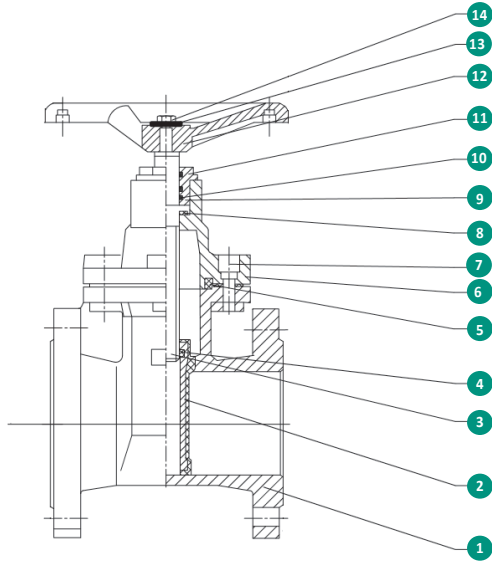

N°	Component	Material
1	Body	Ductile Iron GGG40
2	Wedge	Ductile Iron GGG40 + WRAS EPDM
3	Stem	Stainless Steel 2Cr13
4	Stem nut	Brass HMn58-2
5	Sealing ring	WRAS EPDM
6	Bonnet	Ductile Iron GGG40
7	Screw	Gr.8.8
8	Gasket	Brass C83600
9	Gland	Brass HMn58-2
10	O-Ring	WRAS EPDM
11	Dust ring	WRAS EPDM
12	Hand Wheel	Ductile Iron GGG40
13	Washer	Stainless Steel SS304
14	Bolt	Stainless Steel SS304