

FIVC Pressure Gauge

Plastic and Copper Alloy – 0-10 bar – Bourdon – EN 837-1



FPG series

Description

FIVC Pressure Gauge is designed as a Bourdon type device to be installed in applications for pressure-measurement purposes. The device is zero-referenced against ambient pressure and reads zero when it is disconnected from the equipment.

Using a pressure gauge has the advantage of providing fast and accurate fluid pressure readings. Furthermore, the device ensures that no leakages or pressure changes occur in the system, resulting in a predictable and reliable system.

Besides, the pressure gauge is simple and easy to install and may be more durable in rough and large applications with large pressure changes.

Technical data

Main features and materials

- Case: Plastic
 - Process connection: Copper Alloy
 - Pressure element: Copper Alloy
 - Dial: Plastic/Aluminium w/Pointer stop pin
 - Window: Plastic
 - Movement: Copper Alloy
 - USP: Reliable and cost-effective
- Nominal size: 40, 50, 63, 80, 100, and 160
- Design: EN 837-1
 - Accuracy class: 2.5
 - Pressure limitation:
 - Steady: 3/4 x full scale value
 - Fluctuating: 2/3 x full scale value
 - Short time: Full scale value
 - Scale ranges: 0..0.6 to 0..400 bar

Field of applications

- Temperature range:
 - Ambient: -20 to 60 °C
 - Medium: +60 °C maximum
- Max. working pressure: 0-10 bar
- Gaseous and liquid media that are not highly viscous or crystallising and will not attack copper alloy parts
- Pneumatics
- Heating and air-conditioning technology
- Medical engineering

Alternative Product Versions

Other Standards

- Sealings
- Accuracy class 1.6
- Case steel, black, for DN 40, 50 and 63 with blow-out device
- Surface mounting flange (not with DN 40 and 50)

Other versions available upon request.

Declaration

The product has been inspected and tested in accordance with the Sound Engineering Practice SEP. Acc. to the European PED Directive N° 2014/68/EU, dated 15/05/2014, the product is exempted from CE marking (Cf. Art. 4.3). Approvals include GOST, Russia (metrology/measurement technology), CRN, Canada (safety e.g. electr. safety, over-pressure etc.).

Dimensions

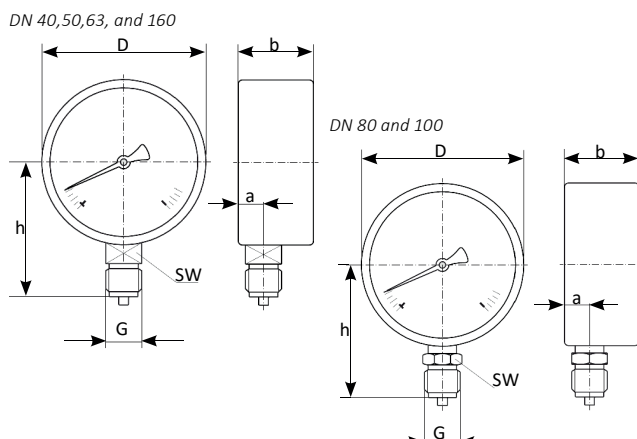

Product code	Size	NS*	a	b±0.5	D	h±1	SW	PC*	Kg
FPGB003P01040	3	40	9.5	26	39	36	14	Male, 14 mm flats	0.08
FPGB006P01050	6	50	10	27.5	49	45	14		0.10
FPGB006P01063	6	63	9.5	27.5	62	53.5	14		0.13
FPGB015P01080	15	80	11.5	30	79	72	22	Male, 22 mm flats	0.18
FPGB015P010100	15	100	11.5	30.5	99	83.5	22		0.21
FPGB015P010160	15	160	15.5	42	160	115.5	22		0.85

Dimensions are in millimeters • PC: Process connection • NS: Nominal size

FIVC Pressure Gauge

Plastic and Copper Alloy – 0-10 bar – Bourdon – EN 837-1

Product Specification

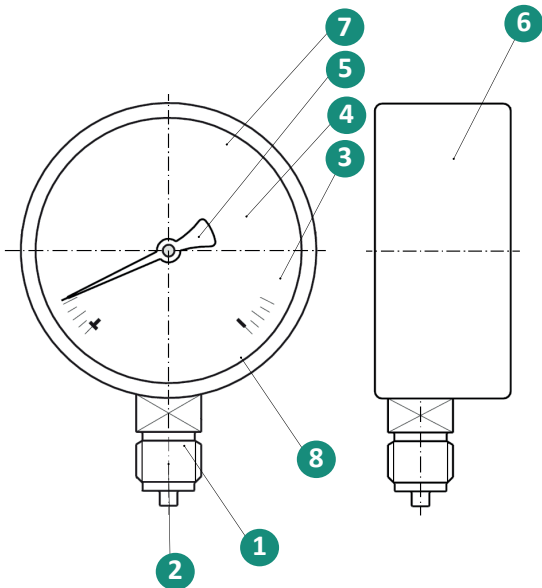

N°	Name	Material
1	Process connection	Copper Alloy, lower mount (LM)
2	Pressure element	Copper Alloy, C-type or helical type
3	Movement	Copper Alloy
4	Dial	DN 40, 50, 63: Plastic, white, with pointer stop pin. DN 80, 100, and 160: Aluminium, white, with pointer stop pin. Black lettering, red mark pointer with measuring ranges 0 ... 0.6 to 0 ... 60 bar.
5	Pointer	Plastic, black. Except DN 160: Steel, black.
6	Case	Plastic, black Except DN 160: Steel, black.
7	Window	Plastic, crystal-clear, snap-fitted in case. Except DN 160: Instrument glass.
8	Bezel ring	DN 40-100: without a bezel ring DN 160: With a bezel ring